



# **INSTRUCTIONS FOR USE**

**BEFORE USING THE REFRIGERATOR**

**SAFEGUARDING THE ENVIRONMENT**

**PRECAUTIONS AND GENERAL RECOMMENDATIONS**

**HOW TO OPERATE THE REFRIGERATOR COMPARTMENT**

**HOW TO OPERATE THE "COOL" COMPARTMENT  
(DEPENDING ON MODEL)**

**HOW TO OPERATE THE FREEZER COMPARTMENT**

**WHEN YOU HEAR THESE NOISES**

**CARE AND MAINTENANCE**

**TROUBLESHOOTING GUIDE**

**AFTER-SALES SERVICE**

**INSTALLATION**

**ELECTRICAL CONNECTION**

## BEFORE USING THE REFRIGERATOR

Your new appliance is a combined ventilated, no-frost fridge-freezer exclusively for domestic use.

The great advantage of this appliance is that the refrigerator and freezer compartments are ventilated, therefore there is no ice or frost formation on the walls, thanks to the process described below. The cold is produced by an evaporator and distributed to the single compartments by means of a fan.

The air, after circulating in the compartments, is absorbed again by the evaporator, which also retains any humidity in the air. This prevents frost from forming on the compartment walls, as in traditional appliances, therefore **there is no need to defrost the appliance.**

The humidity absorbed by the evaporator is transformed into water, which is automatically routed to a container located on the compressor, from where it evaporates. The ventilated refrigeration system guarantees optimal food storage, maintaining the original characteristics longer.

To get the most out of your new appliance, read the user handbook thoroughly. The handbook contains a description of the appliance and useful tips for storing food.

**Keep this handbook** for future consultation.

1. After unpacking the appliance, check for damage and make sure that the doors shut properly. Any damage must be reported to your dealer within 24 hours after delivery of the appliance.
2. **Wait at least two hours without moving the appliance before switching on. This will give the refrigerant circuit time to settle and operate efficiently.**
3. Installation of the appliance and electrical connections must be carried out by a qualified electrician, in accordance with the manufacturer's instructions and local regulations.

## SAFEGUARDING THE ENVIRONMENT

### 1. Packing

The packaging material is entirely recyclable, and marked with the recycling symbol. Follow local regulations for scrapping.

Keep the packaging materials (plastic bags, polystyrene parts, etc.) out of reach of children, as they are potentially dangerous.

### 2. Appliance

The appliance is made using recyclable materials. Disposal must be carried out in accordance with local environmental regulations for waste disposal.

Make the appliance unusable by cutting off the power cord. The appliance must be delivered to an authorized collection centre for the recovery of refrigerant gas.

### Information:

This appliance does not contain CFCs (replaced with R134a) or HFCs (replaced with R600a-Isobutane). For more information, refer to the identification data plate affixed to the appliance.

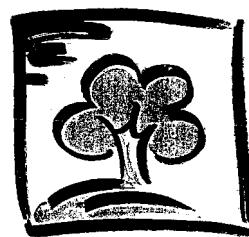

## PRECAUTIONS AND GENERAL RECOMMENDATIONS

- Use the **refrigerator compartment** only for storing fresh food and beverages and use the freezer compartment only for storing frozen food, freezing fresh food and making ice cubes.
- Do not cover or obstruct the air vents of the appliance.
- Do not store liquids in glass containers in the freezer compartment - danger of bursting.
- Do not eat ice cubes or ice lollies immediately after taking them out of the freezer compartment - risk of "cold" burns.
- Do not allow children to play or hide inside the appliance - risk of becoming trapped and suffocating.
- Do not ingest the contents (non-toxic) of the ice packs (if provided).
- **Before any cleaning or maintenance operation, unplug the appliance from the mains or disconnect the electrical power supply.**
- The power cable may only be replaced by an authorised person.
- After installation, make sure that the refrigerator does not stand on the power cable.

### Declaration of conformity

This appliance is intended to come into contact with foodstuffs and conforms to D.L. 108 of 25.01.1992 (European Directive 89/109/EEC).



### Information Appliances with Isobutane (R600a).

Isobutane is a natural gas with low environmental impact. Caution is required, however, since isobutane is flammable. Therefore, it is essential to ensure that refrigerant pipelines are not damaged.

## HOW TO OPERATE THE REFRIGERATOR COMPARTMENT

**The refrigerator compartment is designed for the storage of fresh food and beverages.**

**Defrosting of the refrigerator compartment is completely automatic.**

The refrigerator can operate at ambient temperatures between +10°C and +38°C. Optimal performance is obtained at temperatures between +16°C and +32°C.

### Switching on the appliance

- Plug in the appliance.
- The appliance will switch on automatically.
- The inside light switches on when the refrigerator door is opened.

**To adjust the temperature, follow the instructions in the accompanying chart.**

### Important:

- There is no need to adjust the thermostat knob as the temperature is factory set to ensure the correct storage temperature for fresh foods at ambient temperatures between +20°C and +25°C.
- After being switched on, the refrigerator needs approximately 2 hours to reach the correct temperature to store a typical volume of food in the refrigerator compartment.

**To switch off the appliance, turn the knob (2) to OFF.**

- In models without the "COOL" compartment, air distribution in the lower part of the refrigerator can be adjusted by means of the regulator (4).

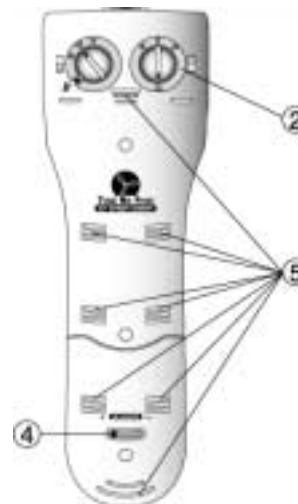

Fig. 1

**How to use the refrigerator compartment**

Position the food as shown in the figure.

- A. Cooked food
- B. Fish, meat
- C. Fruit and vegetables
- D. Bottles
- E. Butter
- F. Dairy products, cheese

To maintain the vitamins, aroma, substance and freshness of the food to be stored, it is advisable to wrap food in aluminium foil, cling film or place it in special freezer containers with lids. This will prevent odours from mixing.

**Important**

Since appliance internal temperature is to all intents and purposes uniform thanks to the new ventilated system (**MULTI-FLOW Fig.1**), foods can be arranged on any shelf; nonetheless, we recommend to arrange the food as shown in **Fig. 2** paying attention not to obstruct the air vents (**5**) **Fig. 1**, so that air can circulate.

Do not place hot food in the refrigerator.



**Fig. 2**

**HOW TO OPERATE THE "COOL" COMPARTMENT (DEPENDING ON MODEL)**

**The appliance is equipped with a "COOL" compartment**

To adjust the temperature, use the adjustment button (**4**)

- Towards position (+) for cooler temperatures.
- Towards position (-) for less cool temperatures.

**Removing the "COOL" department**

To remove the parts for a prolonged period (except normal cleaning operations)

- Remove the upper insulating separator and the basket, as illustrated in the figure.

**From this moment**, the temperature in the zone where the basket has been removed will automatically reach the refrigerator compartment set temperature.

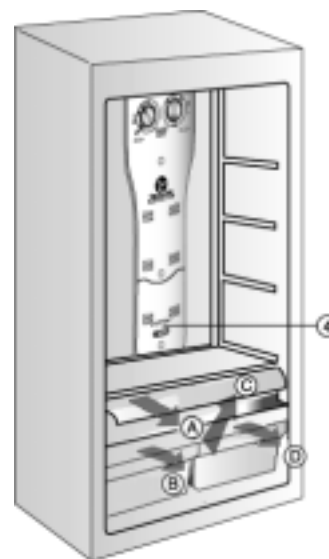

## HOW TO OPERATE THE FREEZER COMPARTMENT

The freezer compartment, marked with the  symbol, can be used for freezing fresh and cooked food, making ice cubes and storing frozen food.

### How to switch on the freezer compartment

- When the appliance is plugged in, the freezer compartment switches on automatically.

### Important:



- There is no need to adjust the thermostat knob as the temperature is factory set to ensure the correct storage temperature for frozen foods in the freezer compartment at ambient temperatures between +20°C and +25°C.
- After switching on, the freezer compartment takes approximately 3 hours to reach a suitable temperature for frozen food storage.

To adjust the temperature, follow the instructions in the accompanying chart.

### How to freeze fresh food

You can use the freezer compartment  to freeze food. The amount of fresh food that can be frozen in 24 hours, at an ambient temperature of + 25°C, is indicated on the data plate.

How to proceed:

1. 24 hours before freezing fresh food, turn the knob (1) to . When turning from Max to , the knob is slightly stiff and the **YELLOW LED (3)** near the symbol  lights up simultaneously.
2. Wrap and seal the food in aluminium foil, cling film, air and water-tight plastic bags, polythene containers with lids, freezer containers.
3. Place food in the drawer, leaving enough space for air to circulate around packs.
4. For more efficient freezing, set the knob (2) to "Max" and use the fast freeze function for the next 24 hours.
5. When freezing is complete, turn the knob (1) back to its original position.

### Note:

- In the event of a power failure, the freezer compartment maintains the correct storage temperature for about 13/14 hours.
- In models with one or two ice packs, this temperature can be maintained for about 18/24 hours.
- Do not open the freezer compartment door during a power failure.

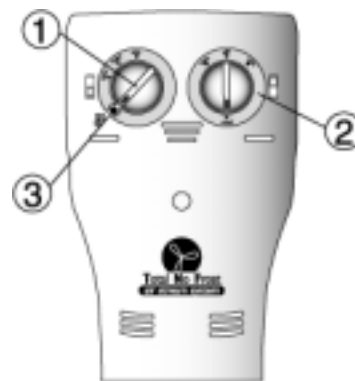

**Important:**

The table alongside shows the recommended maximum storage time for frozen fresh foods.

When purchasing frozen food products:

- Ensure that the packaging is not damaged (frozen food in damaged packaging may have deteriorated). If the package is swollen or has damp patches, it may not have been stored under optimal conditions and defrosting may have already begun.
- When shopping, leave frozen food purchases until last and transport the products in a thermally insulated cool bag.
- Place the items in the freezer compartment as soon as you get home.

**Important:**

- Do not place hot food in the freezer.
- Wrap foods in aluminium foil or cling film or place them in specific containers.
- Ensure all packs placed in the freezer have a label indicating the date of freezing and content.
- If food has defrosted even partially, do not re-freeze it. Consume within 24 hours.
- Avoid, or reduce temperature variations to the minimum.
- Respect the best-before date on the package.
- Always observe the storage information on the package.

**Making ice cubes**

- Fill the ice cube tray 3/4 with water, cover it with the lid supplied and place it at the bottom of the freezer compartment. To speed up the ice making process, place the tray on the bottom of the first drawer (as shown in the figure) and not on the ice pack rack (if provided).
- If the tray sticks to the bottom of the compartment, do not use pointed or sharp instruments to detach it.

MONTHS	FOOD
1-3	
4-7	
8-12	



**WHEN YOU HEAR THESE NOISES**

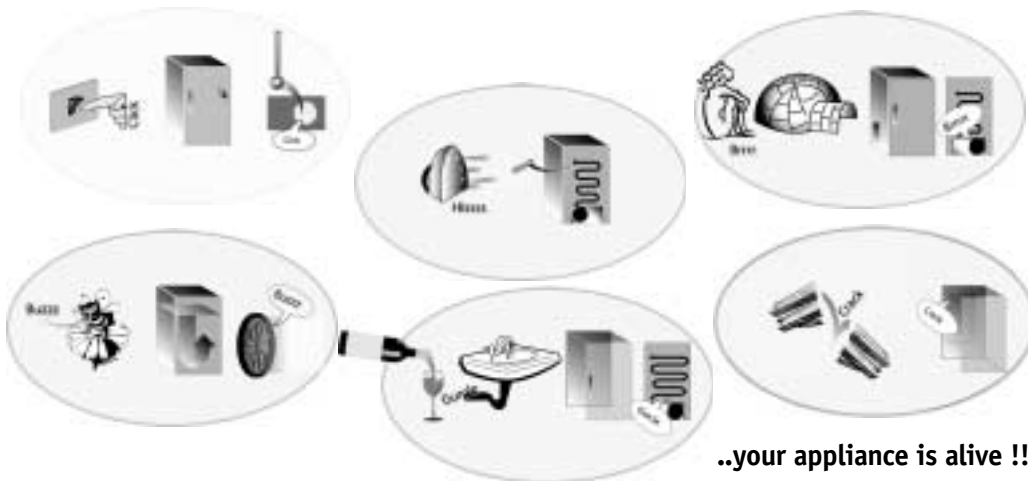

..your appliance is alive !!!

## CARE AND MAINTENANCE

**Before carrying out any cleaning operations, unplug the appliance.**

- Clean the inside of the freezer compartment when defrosting.
- Periodically clean the inside of the refrigerator compartment with a sponge dampened in warm water and/or neutral detergent. Rinse the interior and dry with a soft cloth. Do not use abrasive products.
- Clean the outside with a damp cloth. Do not use abrasive products, scourers, stain-removers (e.g. acetone, trichloroethylene) or vinegar.
- Both refrigerator and freezer compartments are provided with an automatic defrosting function (no frost system).
- **Periodically clean the condenser (radiator) at the rear of the appliance and the plinth with a vacuum cleaner or brush.**

### **Prolonged disuse**

1. Empty the refrigerator and freezer compartments
2. Unplug the appliance
3. Clean and dry both refrigerator and freezer compartments
4. Leave the doors open to prevent formation of unpleasant odours.



## TROUBLESHOOTING GUIDE

### 1. The appliance is not working.

- Is there a power failure?
- Is the plug properly inserted in the socket?
- Is the double-pole switch on?
- Has the fuse blown?
- Is the power cord in perfect condition?
- Is the thermostat set to • (Stop)?

### 2. Temperature inside the compartments is not low enough.

- Are the doors closed properly?
- Is the appliance installed near a heat source?
- Is the thermostat setting correct?
- Are the air circulation grilles blocked?
- Is the condenser clean?

### 3. Temperature inside the refrigerator compartment is too low.

- Is the thermostat setting correct?

### 4. The appliance is excessively noisy.

- Is the appliance in contact with other furniture or objects?
- Are the pipes at the back touching or vibrating?

### 5. The inside light is not working.

Perform the checks for problem 1, and then:

- Disconnect the appliance from the mains power supply.
- Remove the bulb cover.
- Check the bulb and if necessary replace it. Replace using maximum 15W bulb.

**N.B.:** This product uses a special bulb; to replace do not unscrew. Pull towards the inside of the appliance.

#### Notes:

- **The front edge of the appliance may be hot. This prevents the formation of condensation and is not a defect.**

## AFTER-SALES SERVICE

### Before contacting After-Sales Service:

1. See if you can solve the problem yourself with the help of the Trouble-shooting guide.
2. Switch the appliance on again to see if the problem has been solved. If it has not, disconnect the appliance from the power supply and wait for about an hour before switching on again.
3. If the problem persists after this course of action, contact After-sales Service.

### Specify:

- the nature of the problem,
- the model,
- the Service number (the number after the word SERVICE on the data plate on the inside of the appliance),
- your full address,
- your telephone number and area code.

**SERVICE** 0000 000 00000



#### Note:

**The direction of door opening can be changed. If this operation is performed by After-sales Service it is not covered by the warranty.**



## INSTALLATION

- Install the appliance away from heat sources.
- Install the appliance in a dry, well-ventilated place.
- Ensure that the appliance is level. Adjust the front feet if necessary.
- Leave at least 5 cm clearance above the appliance.
- The sides of some models are extended at the rear so the appliance can be placed directly against the rear wall. Otherwise, fit the spacers (if supplied) on the upper part of the condenser at the rear of the appliance. For models without spacer walls, the distance between the unit and the wall must be at least 4.5 cm.
- Clean the inside (see the chapter "Care and Maintenance").
- Fit the accessories supplied.

### Electrical Connection

- Electrical connections must be made in accordance with local regulations.
- Ensure that the voltage indicated on the appliance data plate corresponds to the domestic supply voltage.
- **Regulations require that the appliance is earthed. The Manufacturer declines all liabilities for injury to persons or damage to property resulting from failure to observe these regulations.**
- If the plug and socket are not of the same type, have the socket replaced by a qualified electrician.
- Do not use extension cables, multiple sockets or adapters.

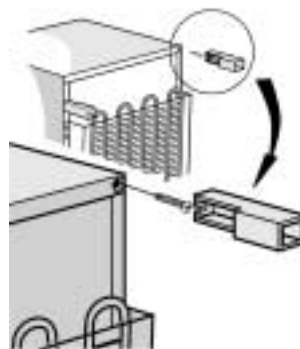
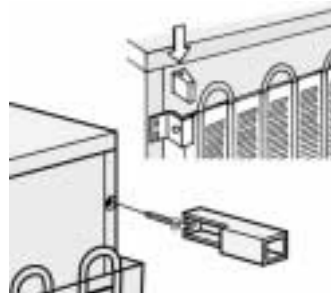

## ELECTRICAL CONNECTION

### 1) For Great Britain only

**Warning - this appliance must be earthed**

#### Fuse replacement

If the mains lead of this appliance is fitted with a BS 1363A 13amp fused plug, to change a fuse in this type of plug use an A.S.T.A. approved fuse to BS 1362 type and proceed as follows:

1. Remove the fuse cover (A) and fuse (B).
2. Fit replacement 13A fuse into fuse cover.
3. Refit both into plug.

#### Important:

The fuse cover must be refitted when changing a fuse and if the fuse cover is lost the plug must not be used until a correct replacement is fitted.

Correct replacement are identified by the colour insert or the colour embossed in words on the base of the plug.

Replacement fuse covers are available from your local electrical store.

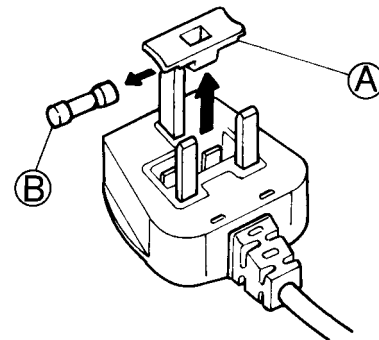

### 2) For the Republic of Ireland only

The information given in respect of Great Britain will frequently apply, but a third type of plug and socket is also used, the 2-pin, side earth type.

### 3) Socket outlet / plug (valid for both countries)

If the fitted plug is not suitable for your socket outlet, please contact Whirlpool Service for further instruction. Please do not attempt to change plug yourself. This procedure needs to be carried out by a qualified Whirlpool technician in compliance with the manufactures instructions and current standard safety regulations.